

COLORBOX - ILLUMINATED ASSESSMENT CABINETS

VF0600, VF1200

MANUAL

1 SAFETY PRECAUTIONS

Please read this manual before operating the product. After reading the manual, store it in a safe place for future reference.

- Not suitable to be put in the sun or in the high light
- Avoid using it in over-high or over-low temperature environment
- Avoid humidity
- Always make sure the instrument is connected to an earthed electric socket.
- Always make sure the instrument's power is turned off while adjusting any electric component



VF0600

2 PRODUCT DESCRIPTION

TQC Colorboxes offer a extensive range of illumination conditions for any visual inspection. The multiple selectable light sources allow assessment of gloss, structure, damages and metamerism. The Colorboxes are available in 60 and 120cm width. All are supplied with removable viewing table and runtime counter. Both interior and exterior are finished to the highest quality standard. The ability to switch between light sources without flickering makes the cabinet extremely stable.



VF1200

2.1 Electrical Parameters

Power supply: AC110-220V, 50/60Hz

Power: less than 300W

Make sure to use an earthed socket.

2.2 Details

1. When you press the key of the A light source, this position will display A, accordingly it displays D65, TL84 When the other lightsources are selected.
2. The timer is for recording how many times you have pressed the key and how long each light source is used accordingly. The lifetime of each light source is 2000 hours, during which its color temperature is most stable and therefore the testing is best .
3. Number of times you have pressed a lightsource key (like A, D65, TL84). In this case the A source has been pressed 30 times.
4. This is the amount of time that a lightsource has been switched ON, in XX(hour)-xx(minute) format.

**2.3 Standards**

Conforming ASTM D1729, ISO3668, ISO3664.

Look up the appropriate standard for a correct execution of the test.

3 FEATURES

- Metamerism test. Through microprocessor, the cabinet can be switched between different light sources instantly to check the color difference of goods under different light sources. When lighting up, there is no flashing as with normal fluorescent lamps.
- Correctly record use time of each lamp group. Especially D65 standard lamp shall be replaced after being used for over 2,000 hrs, avoiding erroneous results due to aged lamp.
- UV light source for checking articles containing fluorescent, optical brighteners or whitening dye, or be used to add UV to D65 light source.
- Both colorboxes come with two daylight light sources, of which D5000 is mainly used in the graphical industry, conform ISO3668.

4 WHAT'S IN THE BOX?

- VF0600 / VF1200 Colorbox plus lightsources;

| | Code | Kelvin/ temperature | Watt | Lamp Type | Use | Description on the lamp | TQC art.nr. |
|--------|-------|------------------------|-------|--------------|--|----------------------------|-------------|
| vf0600 | D65 | 6500K | 2x18W | Fluorescent | International Standard Artificial daylight | D65 18W / 965 | N.a. |
| vf1200 | | | 2x36W | | | D65 36W / 965 | N.a. |
| vf0600 | TL84 | 4000K | 2x18W | Fluorescent | European, Japanese Shop Light Source | TL84 18W / 940 | N.a. |
| vf1200 | | | 2x36W | | | TL84 36W / 940 | N.a. |
| vf0600 | D5000 | 5000K | 2x18W | Fluorescent | International Standard Artificial daylight | D50 18W / 950 | N.a. |
| vf1200 | | | 2x36W | | | D50 36W / 950 | N.a. |
| vf0600 | F/A | 2700K | 4x40W | Incandescent | Domestic light | E27 | N.a. |
| vf1200 | | | 6x40W | | | | |
| vf0600 | UV | (365 nm) | 1x18W | Fluorescent | Ultraviolet light | UV 18W / BLB | N.a. |
| vf1200 | | | 1x37W | | | UV 36W / BLB | N.a. |

N.a. = Not Available as spare part

5 ASSEMBLY INSTRUCTIONS

5.1 Cabinet

The **cabinet** consists of 5 parts:

- 1 Base-panel
- 1 Back-panel
- 2 Side-panels
- 1 Light-canopy

1. Position and screw pre-drilled side-panels to edge of the back panel using the self tapping cup-screws provided. Ensure that the rear edge of the sides lines up with the back – see *diagram A*.
2. Slide base-panel into position.
3. Place all lamps in the correct position:

D50: fluorescent **type 950**
F: bulb type **E27**
D65: fluorescent **type 965**
TL84: fluorescent **type 940**
UV: fluorescent type **BLB**

Check if all lamps are fixed correctly and tight.

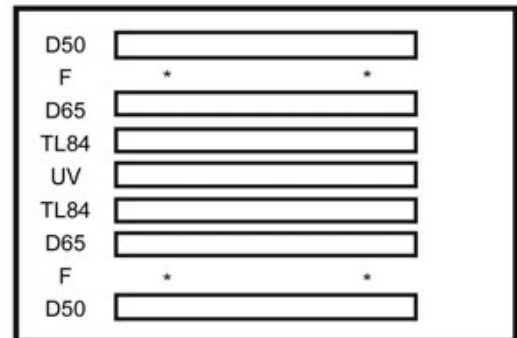

4. Position light-canopy on the top edge of back- and side panels tongue and groove – see *diagram B*.

5.2 Observation table

The **Observation table** consists of 2 parts:

1. Rectangular faceplate with 2 pre-drilled holes
2. Triangular base plate with 2 pre-drilled holes
3. Position the faceplate against the base plate,
4. make sure the pre-drilled holes are lined up.
5. Place and tighten the 2 screws.

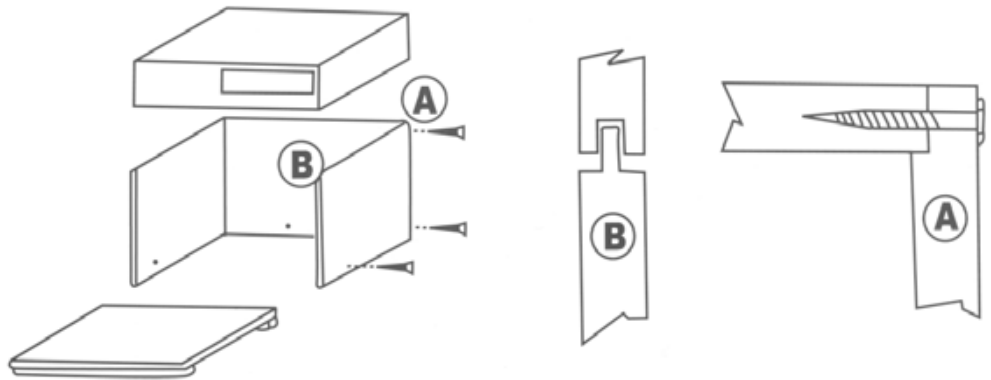

6 HOW TO OPERATE

1. Plug one end of power line into socket at rear of the Colorbox cabinet and the other end into electric supply source 220/230V 50/60 Hz..Switch on the cabinet using the main-switch at the side panel at the right hand side of the Colorbox. The display will indicate that the power is on.
2. Press "ON/OFF" key for one time and the timer will display the total service time of this cabinet.
3. Press D65 key and D65 lamp will light up. The timer displays the total service time of the D65 lamp. Total operating time of each individual light-source F, TL84, or UV is recorded and shown on the timer.

4. In case two or more light sources has to be used at the same time just press two key or more keys simultaneously.
5. Place the items to be checked at the centre of the light cabinet. When comparing the color of two or more items simultaneously, don't observe them by overlapping but place them parallel in the cabinet.
6. It's good practice to observe items in reference to Figure I. If the light is projected at the item in a right angle, one shall observe the item at a 45° angle.
7. When finished press the ON/OFF key to power-off. Power-off the Colorbox using the main-switch at side in case it will not be used during a longer period.
8. Install new lamps as shown in Figure II. Always make sure the right lamps are fitted at the right position. After replacing, zero the operating time of the new lamp as follows:
 - light up new lamp,
 - put a small screwdriver into the central hole of CLR and press the key (Only the timer of the lamp that is lit will be zeroed).
 - It is recommended to exchange (especially D65) the lamps after 2000 hours.

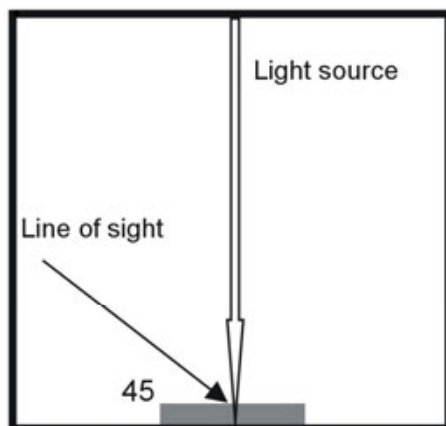

Figure 1

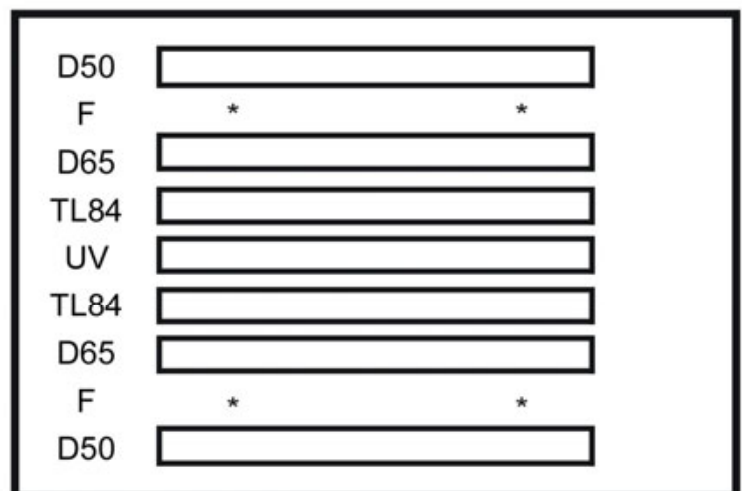

Figure 2

| | |
|-------|----------------------|
| D50: | fluorescent type 950 |
| F: | bulb type E27 |
| D65: | fluorescent type 965 |
| TL84: | fluorescent type 940 |
| UV: | fluorescent type BLB |

Please Note:

- For the best results the cabinet should be located, in a place where glare, extraneous lights and anything which will maladapt the visual response, are avoided. Any windows near the cabinet should be fitted with grey blinds. In the field of view there shouldn't be direct light. Artificial daylight to a level of 200-300 lux should be used to light the vicinity.
- Individuals have slightly different perceptions of certain colours. Therefore it would be advantageous to have a colour perception test for all involved in decision-making regarding colour coordination.

- After starting up the cabinet and start of the assessment the eye should be focused, for at least five minutes on a neutral field of vision, such as the neutral colour of the cabinet.
- After changing from one gaudy object to another, the eyes need time to adapt (time conform the standard).

7 EXTEND THE LIFETIME OF YOUR LAMPS

The lifetime of the lamps depends on the actual operation hours and number of switch on/off cycles. Each time the lamp is switched on/off the lifetime is reduced. Further when the cabinet is to be used several times during the day it is recommended not to switch off the main switch. Only switch to different light sources when needed. If the cabinet is not to be used for period longer than, let's say 4 to 6 hours it is better to switch off the Colorbox using the main switch.

8 MAINTENANCE

- Verify that the lamps do not exceed the maximum number of operational hours as stated in the standard you need to conform to and turning on moments do not exceed the maximum
- Verify that the interior is clean.
- Though robust in design, this instrument is precision-machined. Never drop it or knock it over
- Always clean the instrument after use.
- Clean the instrument using a soft dry cloth. Never clean the instrument by any mechanical means such as a wire brush or abrasive paper. This may cause, just like the use of aggressive cleaning agents, permanent damage.
- Do not use compressed air to clean the instrument.
- Always keep the instrument in its case when not in use.

9 DISCLAIMER

The right of technical modifications is reserved.

The information given in this manual is not intended to be exhaustive and any person using the product for any purpose other than that specifically recommended in this manual without first obtaining written confirmation from us as to the suitability of the product for the intended purpose does so at his own risk. Whilst we endeavour to ensure that all advice we give about the product (whether in this manual or otherwise) is correct we have no control over either the quality or condition of the product or the many factors affecting the use and application of the product. Therefore, unless we specifically agree in writing to do so, we do not accept any liability whatsoever or howsoever arising for the performance of the product or for any loss or damage (other than death or personal injury resulting from our negligence) arising out of the use of the product. The information contained in this manual is liable to modification from time to time in the light of experience and our policy of continuous product development.

v1.07 0917