

MOLDS FOR SAMPLE PREPARATION



MOLDS FOR SAMPLE PREPARATION

Test standard:	Mold item number:
ISO62	THS1390-MLD-61x61x1-ISO62
ISO178	THS1390-MLD-GT-100x200 + Ex
ISO527-2 Type 1 A	THS1390-MLD-10x80-ISO527-2-Type1A-ISO604-TypeB THS1390-MLD-GT-100x200 + Ex
ISO604 Type B	THS1390-MLD-10x80-ISO527-2-Type1A-ISO604-TypeB
ASTM-D395	THS1390-MLD-13x6-ASTM-D395
ASTM-D2229	THS1390-MLD-200x12.5-BISFA-E12-ASTM-D2229
ASTM-D3039	THS1390-MLD-175x25-ASTM-D3039 THS1390-MLD-250x15-ASTM-D3039
ASTM-D3182	THS1390-MLD-150x150x2.5-ASTM-D3182
BISFA-E12	THS1390-MLD-200x12.5-BISFA-E12-ASTM-D2229
GOST26366-Fig.4	THS1390-MLD-212x12.5-GOST26366-Fig.4
GOST26366-Fig.2	THS1390-MLD-2x25-GOST26366-Fig.2 + THS1390-MLD-100g+200g
UL94	THS1390-MLD-GT-100x200 + Ex

Legend:

THS1390-MLD-A-B-C-D

MLD = Mold A, B, C = sample dimensions D = test standard

Contents

THS1390-MLD-10x80-ISO527-2-Type1A-ISO604-TypeB 3

THS1390-MLD-61x61x1-ISO62 4

THS1390-MLD-GT-100x200 + Ex 5

THS1390-MLD-150x150x2.5-ASTM-D3182..... 6

THS1390-MLD-200x12.5-BISFA-E12-ASTM-D2229..... 7

THS1390-MLD-13x6-ASTM-D395..... 8

THS1390-MLD-175x25-ASTM-D3039 9

THS1390-MLD-250x15-ASTM-D3039 9

THS1390-MLD-212x12.5-GOST26366-Fig.4 10

THS1390-MLD-2x25-GOST26366-Fig.2 + THS1390-MLD-100g+200g 11

THS1390-MLD-2x31 Mold for biomaterial..... 12

THS1390-MLD-10x80-ISO527-2-Type1A-ISO604-TypeB

ISO 527-2

Plastics - Determination of tensile properties

Part 2: Test conditions for moulding and extrusion plastics

ISO 604

Plastics - Determination of compressive properties

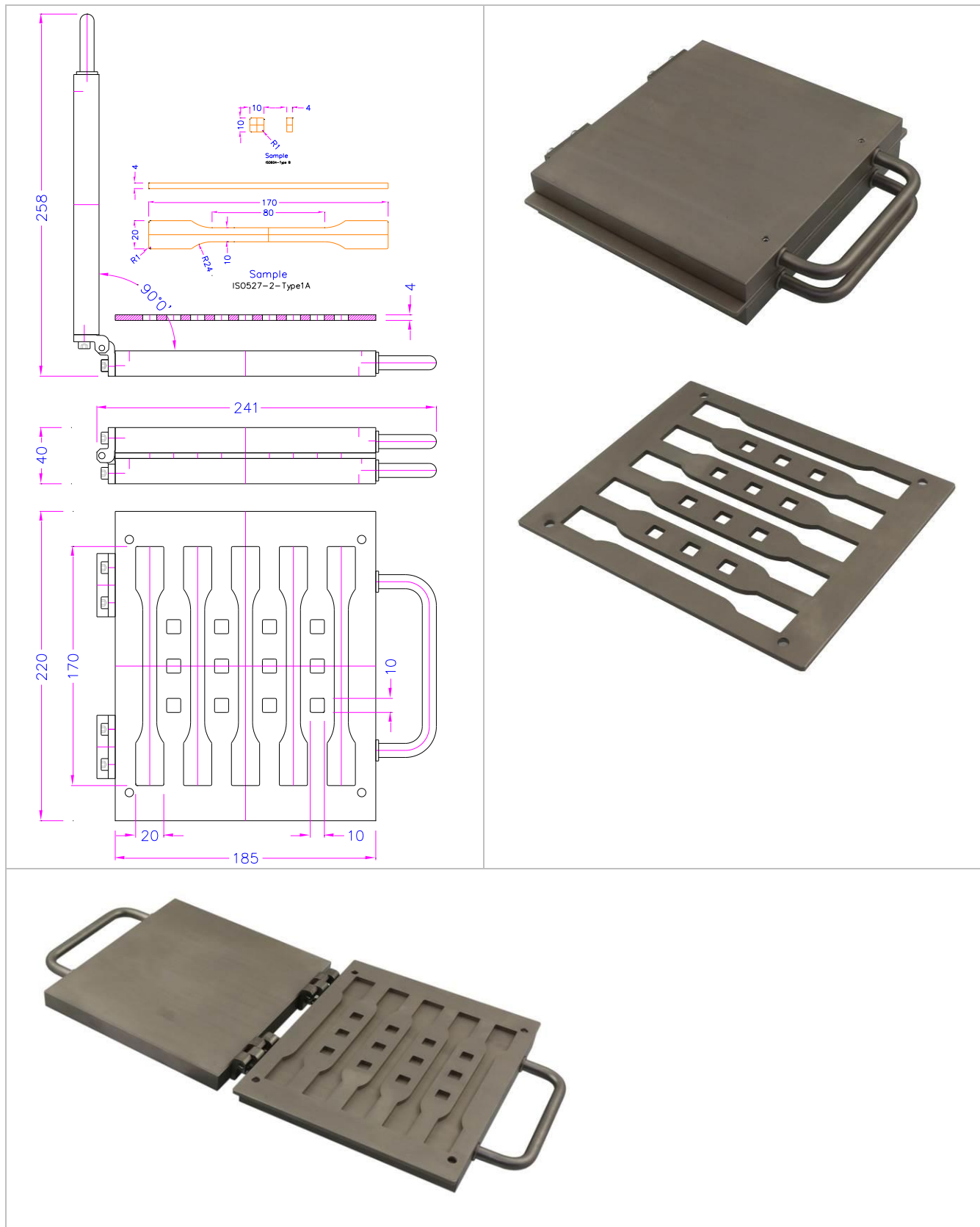

THS1390-MLD-61x61x1-ISO62

Plastics — Determination of water absorption

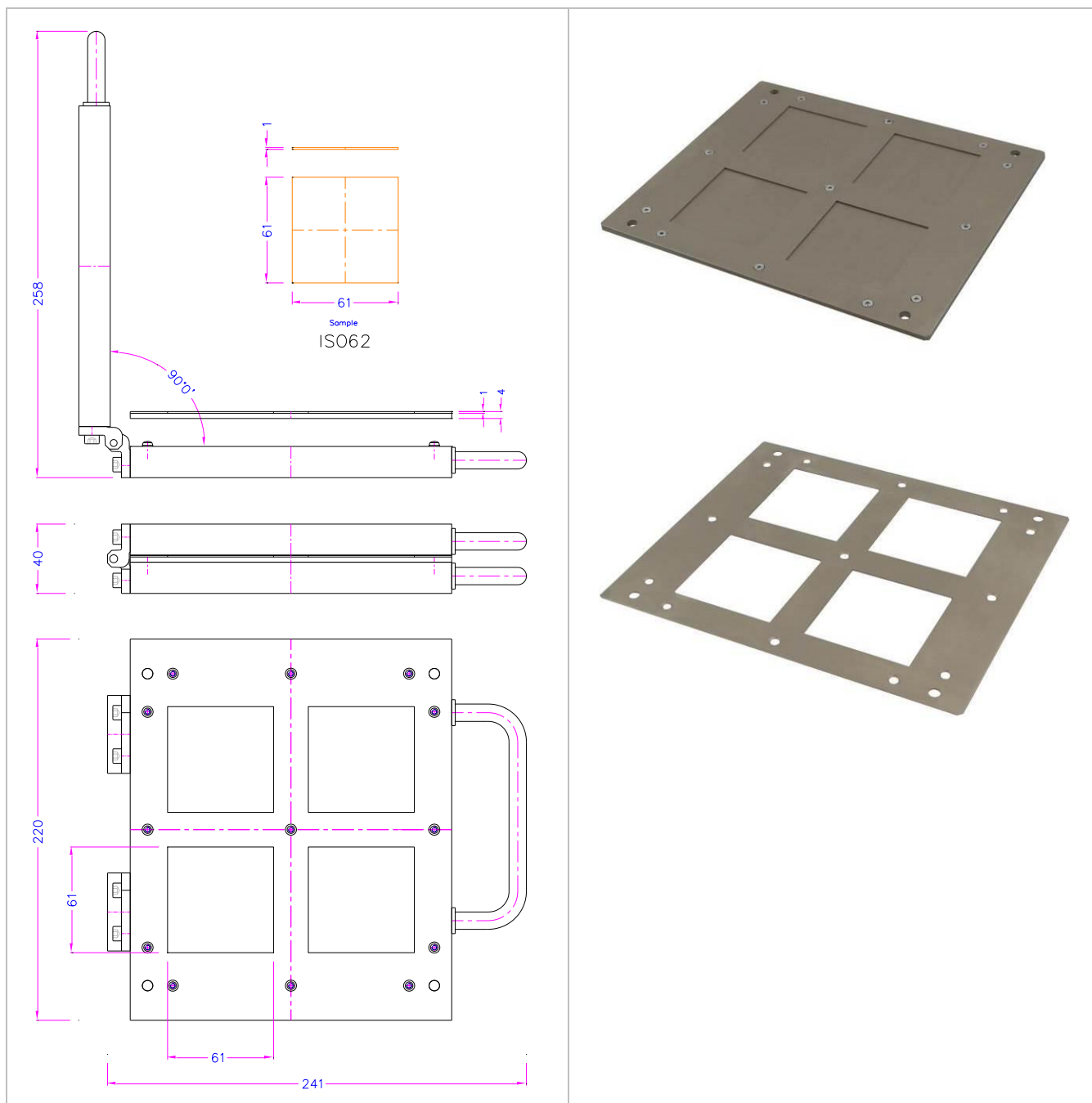

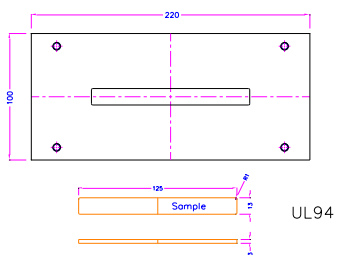

UL94

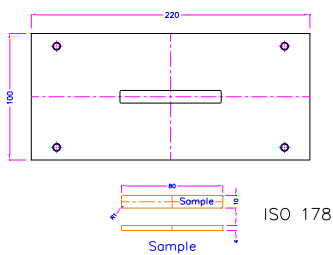

ISO 178

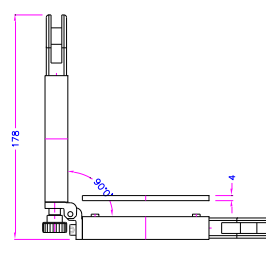

ISO 527-2 Type 1A

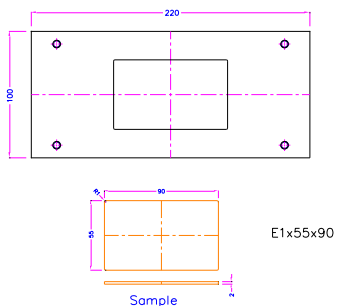

E1x55x90

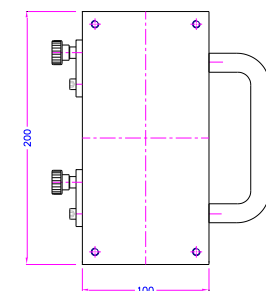
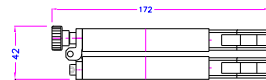

THS1390-MLD-GT-100x200 + Ex

Carrier for inserts:
THS1390-MLD-GT-100x200

Inserts:
THS1390-MLD-E1x10x80-ISO527-2
THS1390-MLD-E1x10x80-ISO178
THS1390-MLD-E1x13x125-UL94
THS1390-MLD-E1x55x90

THS1390-MLD-150x150x2.5-ASTM-D3182

Rubber - Materials, Equipment, and Procedures for Mixing Standard Compounds and Preparing Standard Vulcanized Sheets

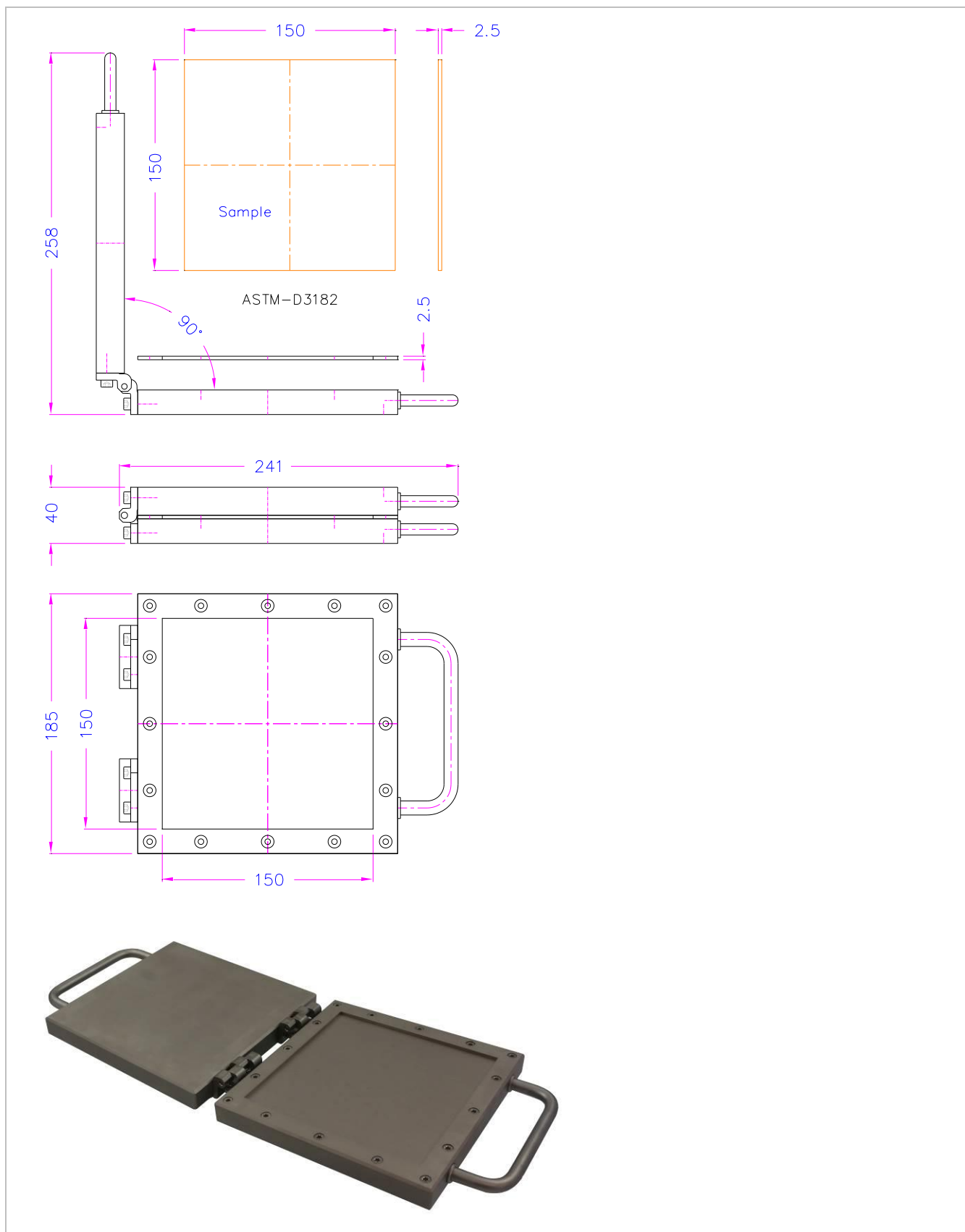

THS1390-MLD-200x12.5-BISFA-E12-ASTM-D2229

Adhesion Between Steel Tire Cords and Rubber

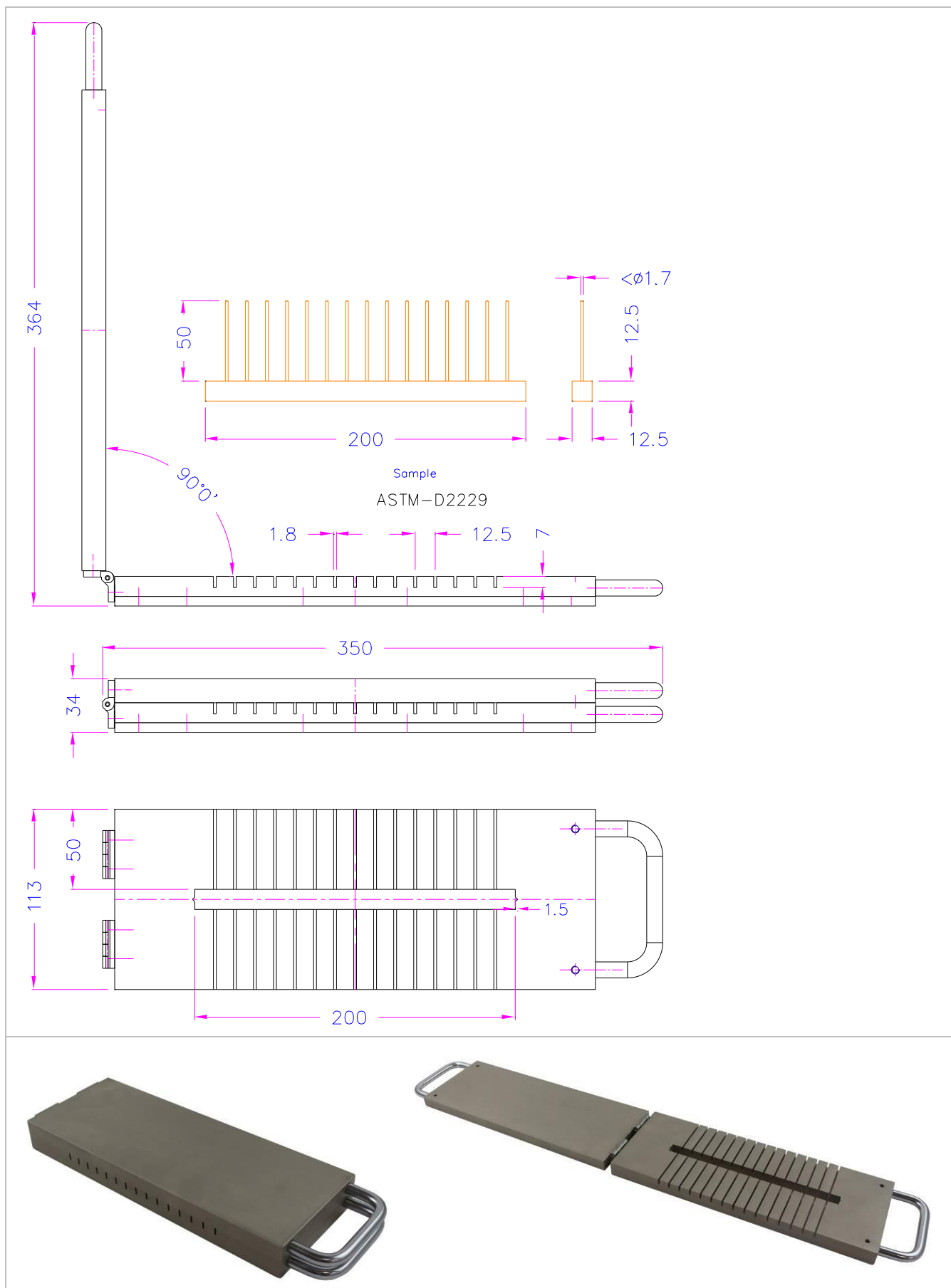

THS1390-MLD-13x6-ASTM-D395
 Rubber Property—Compression Set

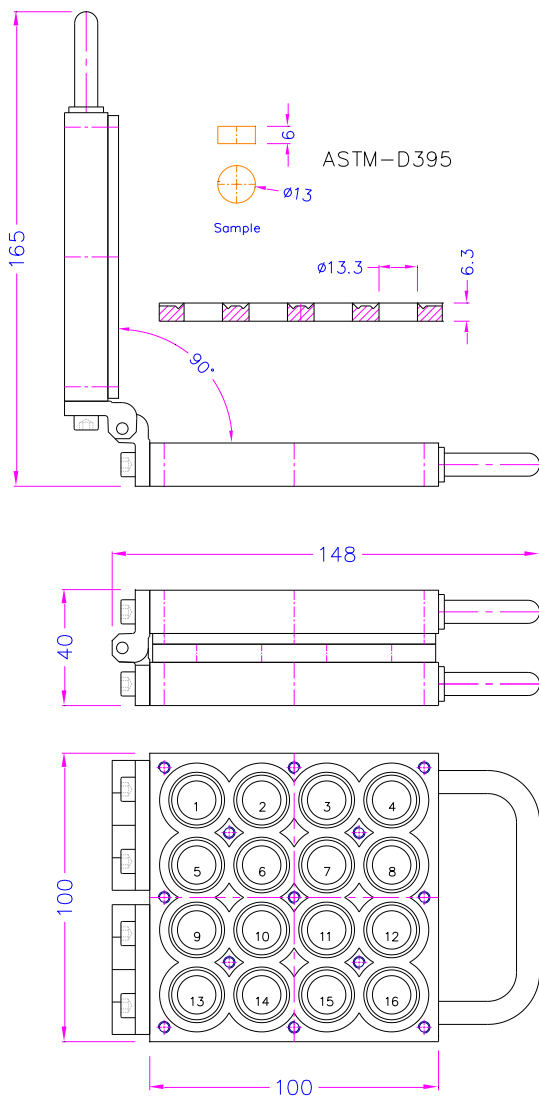

THS1390-MLD-175x25-ASTM-D3039

THS1390-MLD-250x15-ASTM-D3039

Tensile Properties of Polymer Matrix Composite Materials

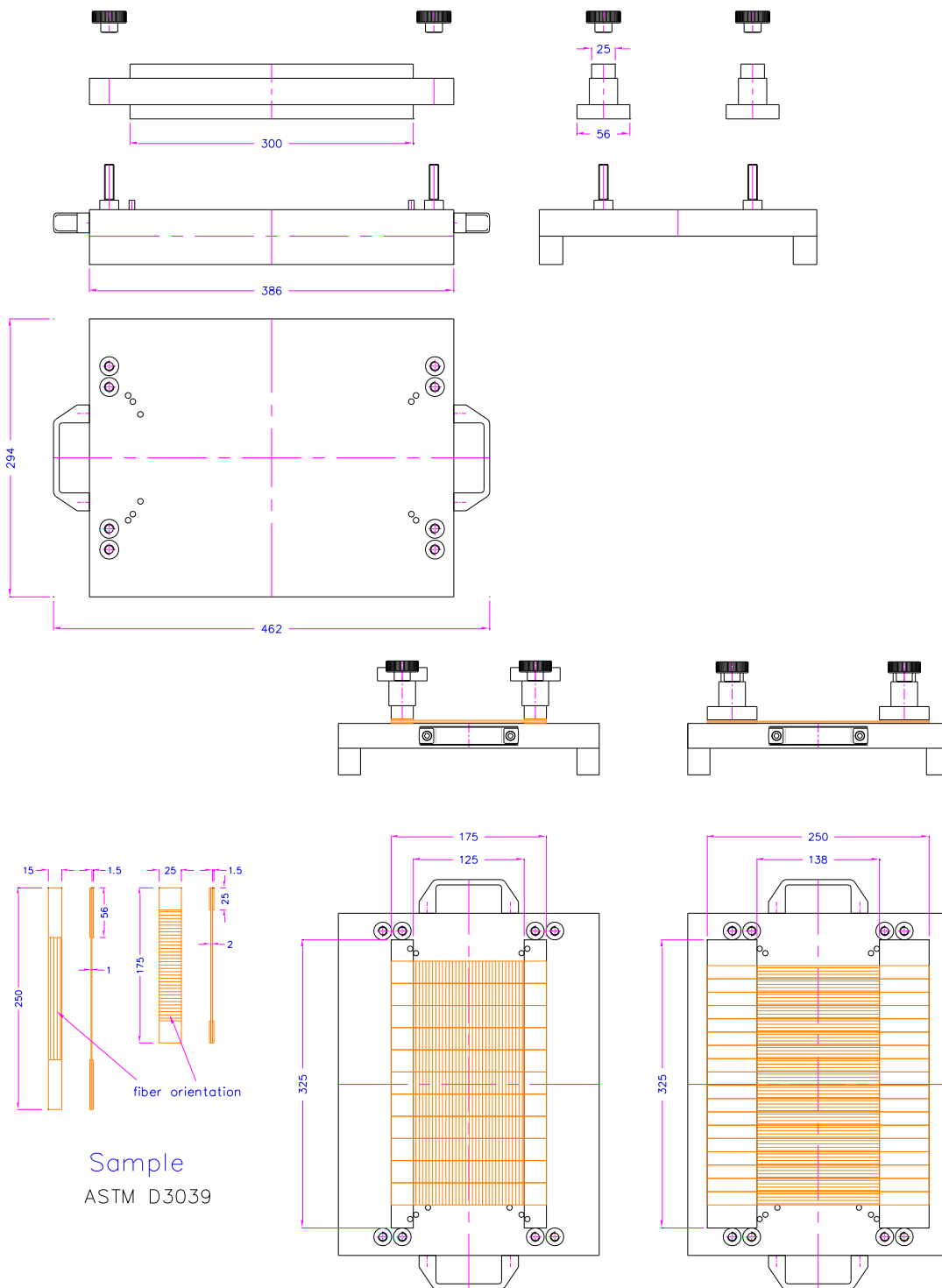

THS1390-MLD-212x12.5-GOST26366-Fig.4
 Brass-plated steel wire for bead rings of tyres. Specifications.

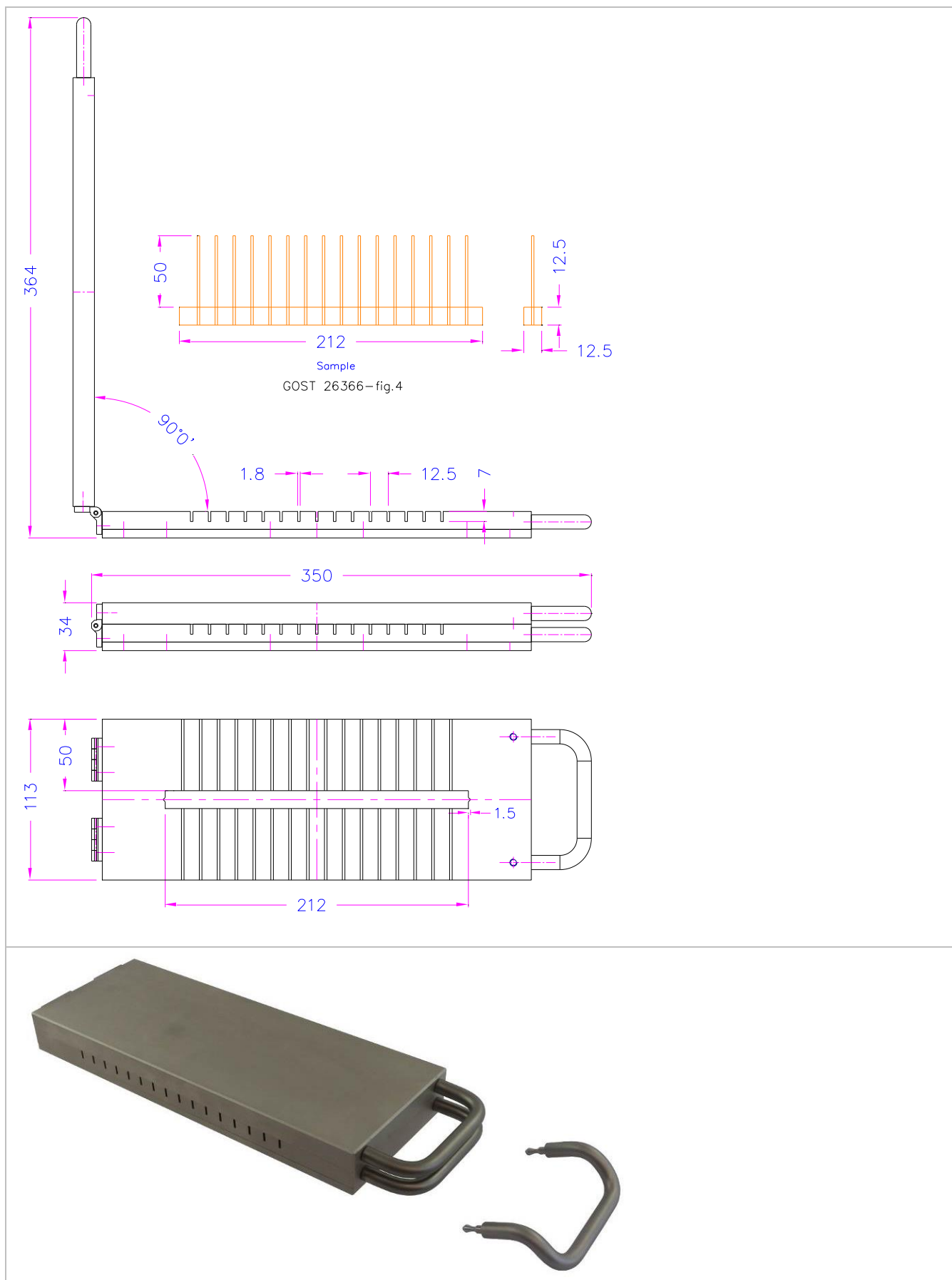

THS1390-MLD-2x25-GOST26366-Fig.2 + THS1390-MLD-100g+200g
 Brass-plated steel wire for bead rings of tyres. Specifications.

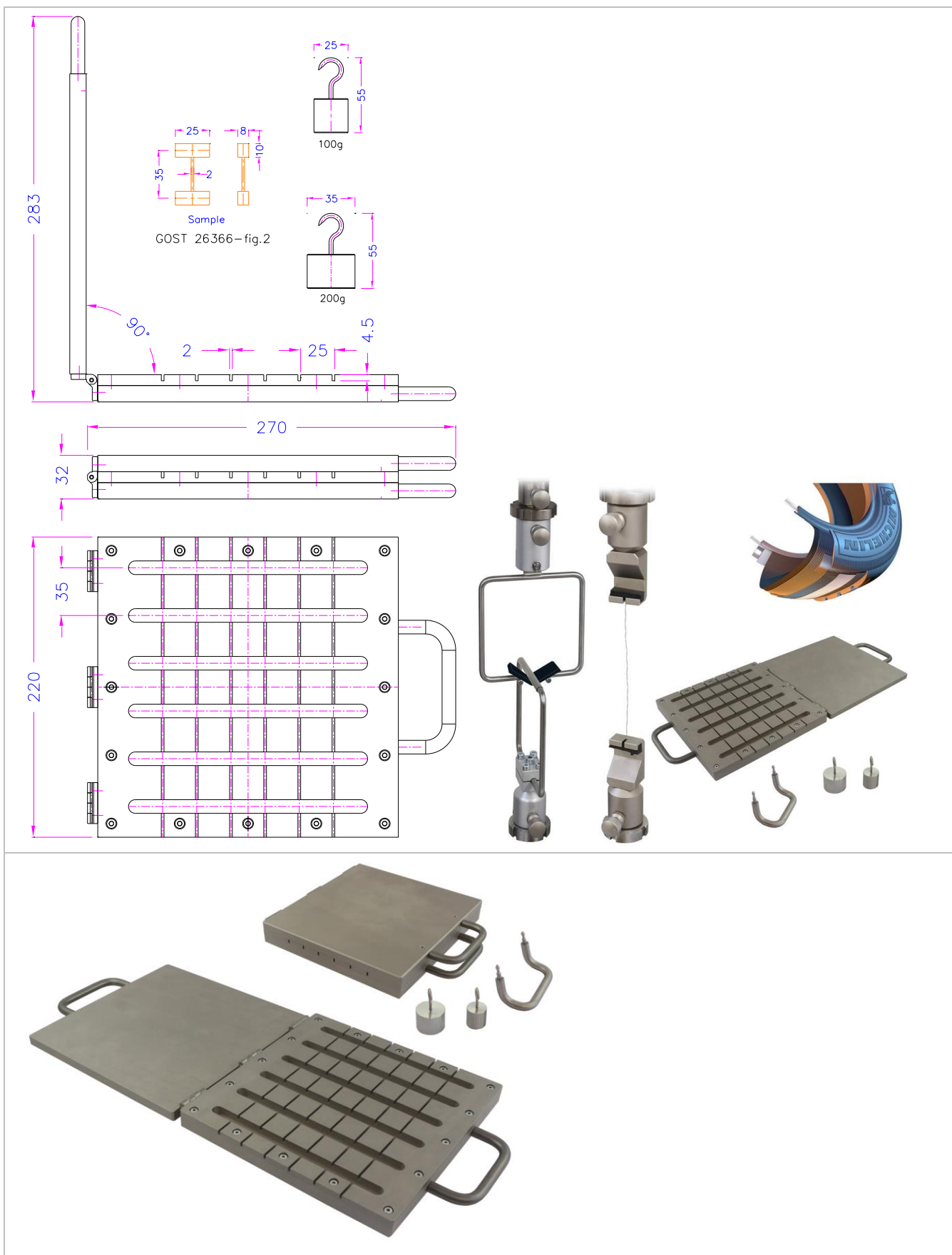

THS1390-MLD-2x31
Mold for biomaterial

